

GRADE F - ZINC PLATED*

" A " COARSE THREAD		" A " FINE THREAD		" B " WIDTH ACROSS FLATS		" C " THICKNESS		" D " FLANGE DIA.	
SIZE	PART NO.	SIZE	PART NO.	MAX.	MIN.	MAX.	MIN.	MAX.	MIN.
1/4-20	SF1420CFZ	1/4-28	---	.438	.428	.236	.222	.560	.530
1/4-20	RF1420CFZ	1/4-28	---	.438	.428	.236	.222	.594	.574
5/16-18	RF51618CFZ	5/16-24	RF51624CFZ	.500	.489	.283	.268	.680	.660
3/8-16	RF3816CFZ	3/8-24	---	.562	.551	.347	.330	.750	.728
7/16-14	RF71614CFZ	7/16-20	---	.688	.675	.395	.375	.937	.910
1/2-13	RF1213CFZ	1/2-20	RF1220CFZ	.750	.736	.458	.437	1.031	1.000
5/8-11	RF5811CFZ	5/8-18	---	.938	.922	.569	.545	1.330	---
3/4-10	RF3410CFZ	3/4-16	---	1.125	1.088	.675	.627	1.585	---
1-8	RF18CFZ	1-14	RF114CFZ	1.500	1.450	.900	.850	2.060	---

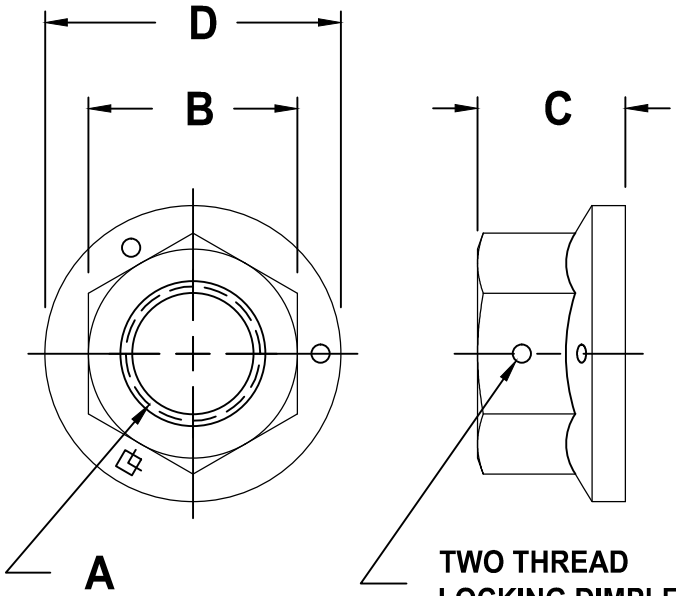

TWO THREAD LOCKING DIMPLES FOR PREVAILING TORQUE SHAPE AS SHOWN

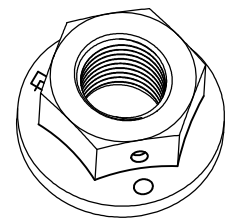

NOTES:
1 - MECHANICAL AND PERFORMANCE REQUIREMENTS PER IFI 100/107

* COMMON FINISHES LISTED - OTHER FINISHES AVAILABLE

FLANGE NUT
CENTERLOCK
GRADE F



SCALE	UNITS	DWG TYPE	REV
NONE	INCH	S	NONE