

GRADE F - ZINC PLATED\*

" A " COARSE THREAD		" A " FINE THREAD		" B " WIDTH ACROSS FLATS		" C " THICKNESS		" D " FLANGE DIA.
SIZE	PART NO.	SIZE	PART NO.	MAX.	MIN.	MAX.	MIN.	MAX.
1/4-20	LF1420TFZ	--	---	.438	.428	.312	.281	.728
5/16-18	LF51618TFZ	--	---	.500	.489	.375	.343	.820
3/8-16	LF3816TFZ	--	---	.562	.551	.406	.390	.915
1/2-13	LF1213TFZ	--	---	.750	.736	.515	.485	1.205

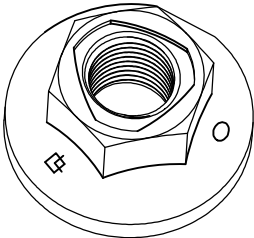
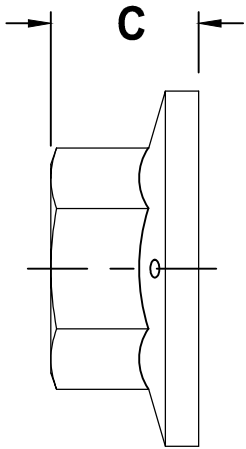
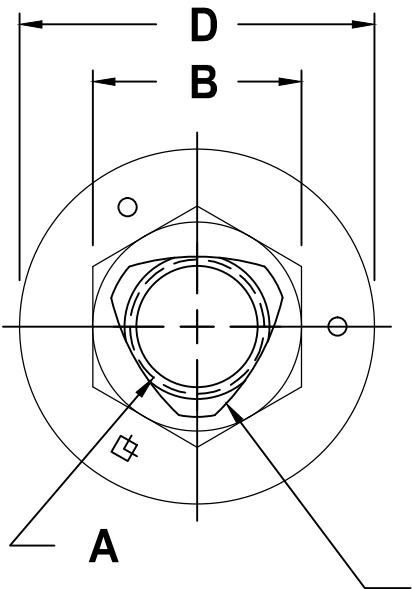

TRIANGULAR DEPRESSION FOR PREVAILING TORQUE SHAPE AS SHOWN

NOTES:

1 - MECHANICAL AND PERFORMANCE REQUIREMENTS PER IFI 100/107

\* COMMON FINISHES LISTED - OTHER FINISHES AVAILABLE

**LARGE FLANGE NUT**  
**TOP LOCK**  
**GRADE F**



SCALE	UNITS	DWG TYPE	REV
NONE	INCH	S	NONE