

GRADE A - ZINC PLATED*							
" A " COARSE THREAD		" A " FINE THREAD		" B " WIDTH ACROSS FLATS		" C " THICKNESS	
SIZE	PART NO.	SIZE	PART NO.	MAX.	MIN.	MAX.	MIN.
4-40	MH440TAZ	--	---	.250	.241	.098	.087
6-32	MH632TAZ	--	---	.312	.302	.114	.102
8-32	MH832TAZ	--	---	.344	.332	.130	.117
10-24	MH1024TAZ	10-32	MH1032TAZ	.375	.362	.130	.117
12-24	MH1224TAZ	12-28	---	.438	.423	.161	.148
1/4-20	MH1420TAZ	1/4-28	---	.438	.423	.193	.178

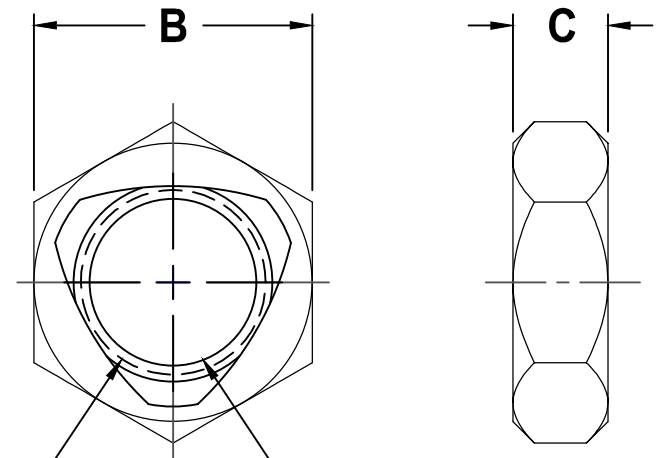

TRIANGULAR DEPRESSION FOR PREVAILING TORQUE SHAPE AS SHOWN

NOTES:
 1 - MECHANICAL AND PERFORMANCE REQUIREMENTS PER IFI 100/107

*** COMMON FINISHES LISTED - OTHER FINISHES AVAILABLE**
 ** ABOVE ITEM AVAILABLE IN OTHER MATERIAL(BRASS, STAINLESS, ETC)

MACHINE SCREW
TOP LOCK
GRADE A

LOCKNUT TECHNOLOGY INC.

SCALE	UNITS	DWG TYPE	REV
NONE	INCH	S	NONE